



Ausgußventil in Eckform , GS-Rg
PN 16 , DN 15 - 400 , max. 225 °C

Mit Abnahme durch Klassifikationsgesellschaften

discharge valve in angle form , GSC25- bronze
PN 16 , DN 15 - 400 , max. 225 °C

with classification test

Teil Part	Bezeichnung Partname	Werkstoff Material	Werkst.Nr. Mat.No
1	Gehäuse body	GS-C25	1.0619
2	Deckel bonnet	GS-C25	1.0619
3	Sitzring seat ring	GZ-Cu Sn5 Zn Pb	2.1096.03
4	Kegel disk	G-Cu Sn5 Zn Pb	2.1096.01
5	Spindel spindle	Cu Sn 8 prägepoliert burnished	2.1030
6	Kurbel crank	GG 25 / cast iron	0.6025
7	Stopfbuchspackung gland packing	Graphit/graphite	
8	Stiftschraube studs	Ck 35	1.1181
9	Sechskantmuttern hexagon nuts	C 35	1.0501
10	Flachdichtung flat seal	Graphit/graphite	

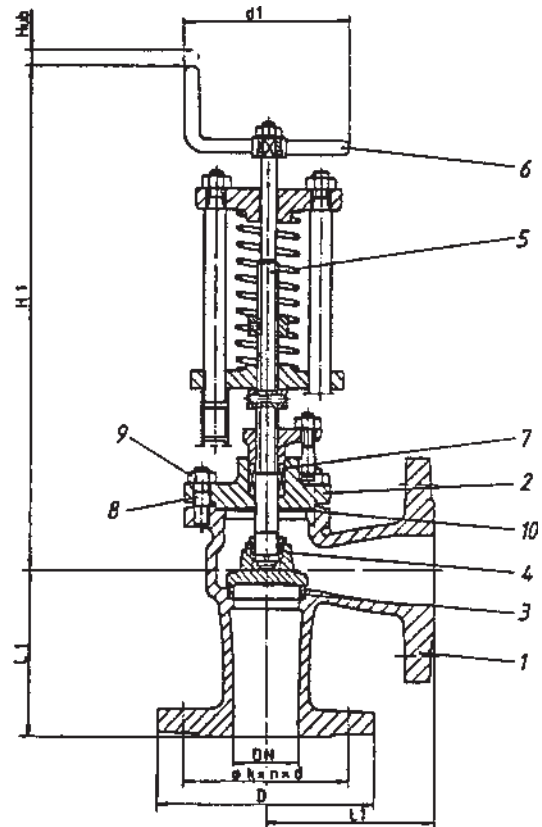

DN	L 1	H 1	d1	D	ø kxnx d	Hub	kg				Art.- Nr.
15	90	320	140	95	65 x 4 x 14	8	7				0127432015
20	95	320	140	105	75 x 4 x 14	8	7				0127432020
25	100	320	140	115	85 x 4 x 14	12	7				0127432025
32	105	320	140	140	100 x 4 x 18	15	9				0127432032
40	115	334	140	150	110 x 4 x 18	20	10				0127432040
50	125	337	140	165	125 x 4 x 18	20	14				0127432050
65	145	450	140	185	145 x 4 x 18	27	17,5				0127432065
80	155	464	140	200	160 x 8 x 18	31	30				0127432080
100	175	482	180	220	180 x 8 x 18	35	38,5				0127432100
125	200	513	180	250	210 x 8 x 18	49	52				0127432125
150	225	685	225	285	240 x 8 x 22	53	69,5				0127432150
175	250	745	225	315	270 x 8 x 22	65	100				0127432175
200	275	745	225	340	295 x 12 x 22	72	115				0127432200
250	325	775	225	405	355 x 12 x 26	80	199				0127432250
300	375	790	225	460	410 x 12 x 26	100	259				0127432300
350	425	970	300	520	470 x 16 x 26	105	392				0127432350
400	475	1100	300	580	525 x 16 x 30	125	630				0127432400
500				auf	Anfrage /	on	request				