

BELLOW SEALED STOP VALVE

DN 15-150

PN 16



FAK-ARMATUREN Hamburg
Valve supplier for industry and shipbuilding

ART. NO.	MATERIAL
0130021...	GGG 40.3
0130031...	GS-C25

// TECHNICAL DRAWINGS

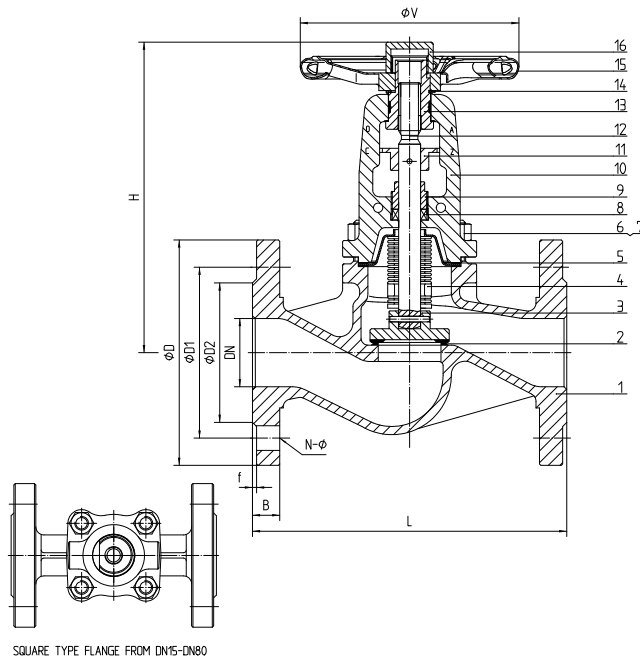

// GENERAL FEATURES

- ◆ Design and manufacture according to BS EN 13709
- ◆ Test pressure according to standards: BS EN 12266
- ◆ Face to face according to BS EN 558-1
- ◆ Flange according to BS EN 1092-B1

// DIMENSIONS

DN	L	ØD	D1	D2	ØB	f	N-Ø	H	ØV
15	130	95	65	45	16	2	4×14	193	120
20	150	105	75	58	18		4×14	193	140
25	160	115	85	68	18		4×14	200	140
32	180	140	100	78	18		4×18	200	140
40	200	150	110	88	18	3	4×18	225	160
50	230	165	125	102	20		4×18	228	160
65	290	185	145	122	18		4×18	242	180
80	310	200	160	138	20		8×18	270	200
100	350	220	180	158	20		8×18	355	250
150	480	285	240	212	22		8×22	420	350

unit: mm

// MATERIAL SPECIFICATIONS

ITEM	PARTS	MATERIAL
①	BODY	GS-C25
②	SEAT SURFACE	X20CR13
③	DISC + SEAT SURFACE	X20CR13
④	BELLOWS SEAL	PTFE
⑤	GASKET	SS304+GRAPHITE
⑥	HEXAGON NUT	ASTM A193 B7
⑦	BOLTS	ASTM A194 2H
⑧	STEM	A182-F 304
⑨	PACKING	GRAPHITE
⑩	GLAND	1.0460
⑪	BONNET	GS-C25
⑫	NO ROT DEVICE	SS301
⑬	STEM	X20CR13
⑭	YOKE NUT	GGG40.3
⑮	CIRCLIP	65MN
⑯	HANDWHEEL	STEEL
⑰	LOCK NUT	C22.8