

SELF-CLOSING VALVE WITH LEVER AND WEIGHT GGG 40.3/ST. STEEL



FAK-ARMATUREN Hamburg
Valve supplier for industry and shipbuilding

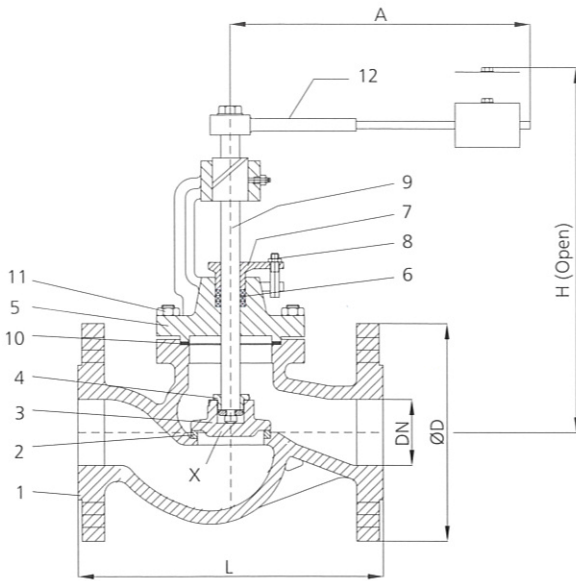

Fig. 1 Straight type

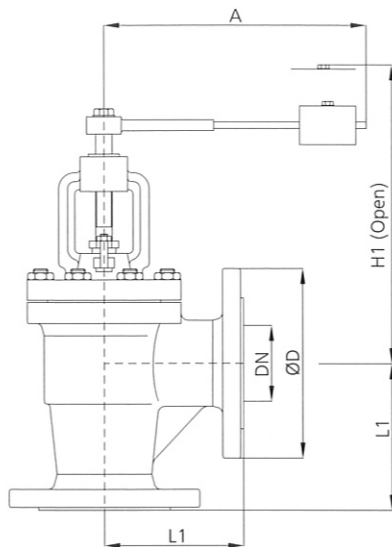

Fig. 2 Angled type

* Flanged ends acc.to DIN EN 1092-2 PN 16 (DIN 2501)

* Face to face acc.to DIN EN 558-1 (DIN 3202 F1-F32)

* Nominal pressure of the valves bodies :

DN 15 - DN 80 = 16 bar

* Materials

Fig.1	01 600 21 ...
Fig.2	01 601 21 ...

No.	Part Name	GGG 40.3 / St.Steel
1	Body	GGG 40.3
2	Seat	X5CrNi 18 9
	Disc (<=50)	X5CrNi 18 9
3	Disc (>65)	GGG 40.3
	Disc Surface	X5CrNi 18 9
4	Disc Nut	X5CrNi 18 9
5	Bonnet	GGG 40.3
6	Packing	Graphite
7	Gland	GGG 40.3
8	TStud,Nut	Steel
9	Spindle	X5CrNi 18 9
10	Gasket	Carbo (Asbestos Free)
11	Stud,Nut	Steel
12	Handlever	GGG 40.3

* Application : For fuel - oil

X Detail

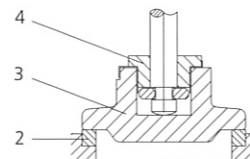

Stop Disc

PN	DN	15	20	25	32	40	50	65	80
	L	130	150	160	180	200	230	290	310
	L1	90	95	100	105	115	125	185	200
16	ØD	95	105	115	140	150	165	185	200
	H (Open)	200	200	210	210	253	266	287	328
	H1 (Open)	189	189	193	193	238	246	267	298
	A	230	230	230	250	250	280	310	310
	kg Fig. 1	5,8	6,7	6,8	9,2	14,2	15,5	20	26,4
	kg Fig. 2	5.3	6,2	6,2	8,4	13	14,2	19	24