

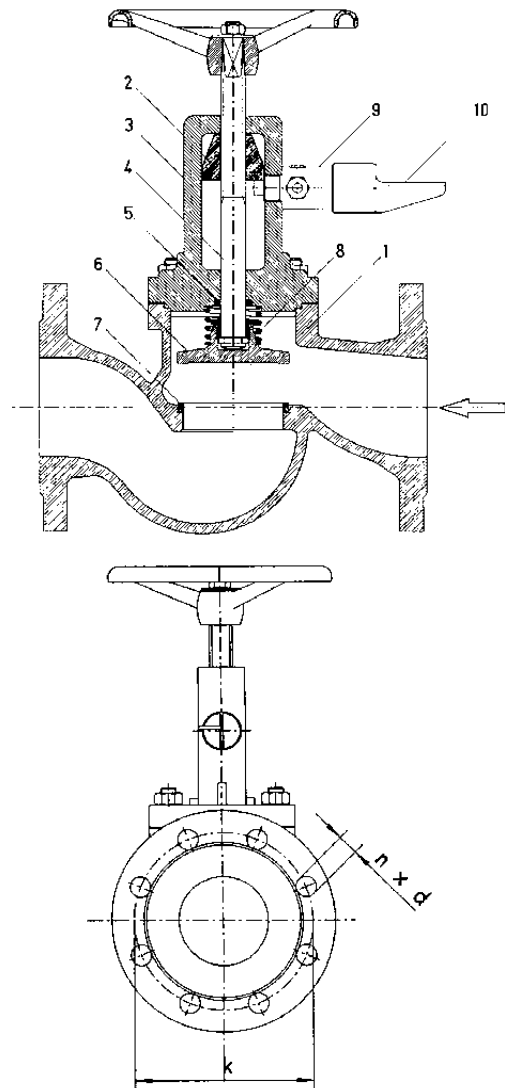

Flanschen - Feder - Schnellschlußventil, mit Absperrung, DN 15 - 200 mit mechanischer, pneumatischer oder hydraulischer Auslösung in Durchgangsform, GSC 25, PN 16

quick closing valve, with flanges and spring, with screw down device, DN 15 - 200 with mechanical, pneumatic or hydraulic relieve, straight form, GSC 25, PN 16

Teil part	Bezeichnung partname	Werkstoff material	Werkst. Nr. material no.
1	Gehäuse body	GSC 25 cast steel	1.0619
2	Mutter nut	CuZn39Pb3	2.0401
3	Oberteil upper part	GSC 25 cast steel	1.0619
4	Spindel spindle	C20Cr13	1.4021
5	Dichtung seal	FPM Fluorine elastomere	
6	Kegel disc	C20Cr13	1.4021
7	Sitzring seat	C20Cr13	1.4021
8	Feder spring	X10CrNi18-8	1.4310
9	Zylinder cylinder	CuZn39Pb3	2.0401
10	Handhebel handlever	S235JR	1.0037



PN 16

DN	H	L	Hub	A	Ø k x n x d	Art.- Nr. pneumatisch	Art.- Nr. hydraulisch
15	168	130	6	164	65 x 4 x 14	01 0650 031 0015	01 0652 031 0015
20	170	150	7	164	75 x 4 x 14	01 0650 031 0020	01 0652 031 0020
25	170	160	8	164	85 x 4 x 14	01 0650 031 0025	01 0652 031 0025
32	212	180	10	164	100 x 4 x 18	01 0650 031 0032	01 0652 031 0032
40	225	200	13	166	110 x 4 x 18	01 0650 031 0040	01 0652 031 0040
50	225	230	16	166	125 x 4 x 18	01 0650 031 0050	01 0652 031 0050
65	278	290	21	166	145 x 4 x 18	01 0650 031 0065	01 0652 031 0065
80	305	310	25	171	160 x 8 x 18	01 0650 031 0080	01 0652 031 0080
100	355	350	32	176	180 x 8 x 18	01 0650 031 0100	01 0652 031 0100
125	450	400	40	176	210 x 8 x 18	01 0650 031 0125	01 0652 031 0125
150	520	480	47	176	240 x 8 x 22	01 0650 031 0150	01 0652 031 0150
200	530	600	70	183	295 x 12 x 22	01 0650 031 0175	01 0652 031 0175