



FAK-ARMATUREN GmbH

Keilflachschieber aus Sphäroguß - Niro, mit Anzeiger
DN 40 - 600 / PN 16 , DIN 3352

gate valve of nodular cast iron - st.steel, with indicator
DN 40 - 600 / PN 16 , DIN 3352

Teil Part	Bezeichnung Partname	Werkstoff Material	Werkst.Nr. Mat.No.
1	Gehäuse body	GGG 40/nod. c.i.	0.7040
2	Deckel bonnet	GGG 40/nod.c.i.	0.7040
3	Keil wedge	GGG 40/nod.c.i.	0.7040
4	Stopfbuchsbrille flange of gland	GGG40/nod.c.i.	0.7040
5	Sitzring / Keil valve seating	Niro/st.steel	1.4401
6	Sitzring / Gehäuse valve seating	Niro/st.steel	1.4401

Teil Part	Bezeichnung Partname	Werkstoff Material	Werkst.Nr. Mat.No.
7	Spindel spindle	X Cr 13 Mo	1.4021
8	Keilmutter wedge - nut	So Ms	2.0540
9	Spindelhalter spindle securing	GGG40	0.7040
10	Scheibe disc	PTFE verst.	

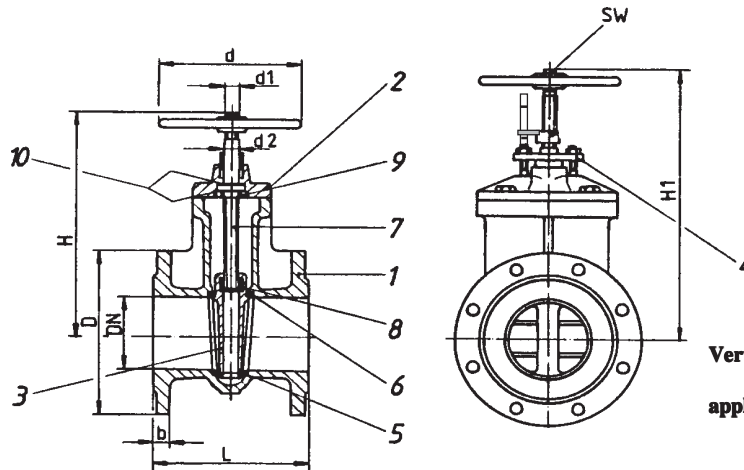

Verwendung: Frischwasser, Seewasser, Schmieröl, Treiböl, Dampf

application: freshwater, seawater, lubricating oil, fuel oil, steam

DN	L	ca.H	D	b	d 1	kg		k x n x d		PN	Art.-Nr.
40	140	265	150	18	160	11		110 x 4 x 18		16	0210121040
50	150	270	165	20	160	12		125 x 4 x 18			0210121050
65	170	295	185	20	160	17		145 x 4 x 18			0210121065
80	180	325	200	22	160	20		160 x 8 x 18			0210121080
100	190	365	220	22	200	25		180 x 8 x 18			0210121100
125	200	440	250	24	250	39		210 x 8 x 18			0210121125
150	210	490	285	24	250	49		240 x 8 x 22			0210121150
200	230	610	340	26	250	76		295 x 12 x 22		10	0210121200
250	250	730	395	28	315	116		355 x 12 x 26			0210121250
300	270	850	445	28	315	156		410 x 12 x 26			0210121300
350	290	950	505	30	400	210		470 x 16 x 26		6	0210121350
400	310	1025	565	32	400	265		525 x 16 x 30			0210121400
500	350	1280	670	34	500	420		650 x 20 x 30			0210121500
600	390	1475	780	36	500	575		770 x 20 x 36			4