

2-PC. SCREWED END BALL VALVE

ART. NO.	MATERIAL
03 006 63...	BSP
03 007 63...	NPT



FAK-ARMATUREN Hamburg
Valve supplier for industry and shipbuilding

// TECHNICAL DRAWINGS

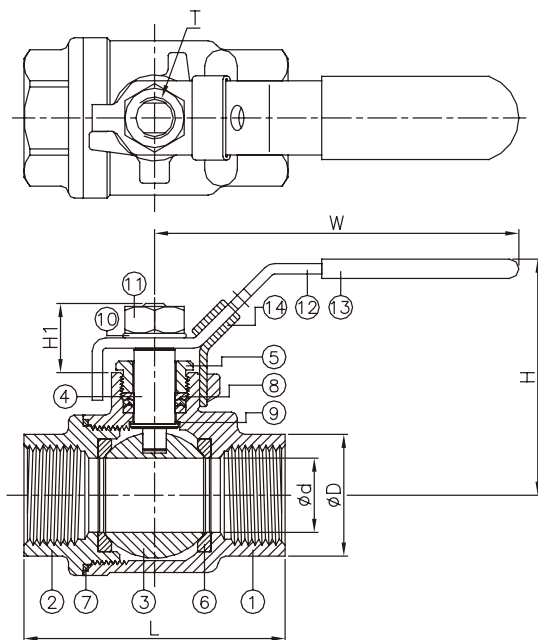

// GENERAL FEATURES

- ◆ Full port, 1/4" ~ 3" (DN8 ~ DN80)
- ◆ W.P.: 1000 WOG (PN63)
- ◆ W.T.: -20°C ~ 200°C (-4°F ~ 392°F)
- ◆ Investment casting
- ◆ Blow-out proof stem
- ◆ Locking device
- ◆ Tapped & drilled mounting pad (option)
- ◆ TA-Luft approved (option)
- ◆ Length conform to DIN 3202/4-M3-2006SM3 (option)
- ◆ Thread type: ASME B1.20.1 (NPT)
DIN2999 & BS21
ISO7/1 & EN10226

// MATERIAL SPECIFICATIONS

ITEM	PARTS	MATERIAL	
①	BODY	ASTM A351-CF8M	ASTM A216-WCB
②	CAP		
③	BALL	ASTM A351-CF8M	
④	STEM	ASTM A276-316	
⑤	GLAND	AISI 304	
⑥	SEAT	PTFE / RTFE	
⑦	SEAL		
⑧	PACKING	PTFE	
⑨	THRUST WASHER		
⑩	SPRING WASHER		
⑪	NUT	AISI 304	
⑫	HANDLE		
⑬	HANDLE SLEEVE	PVC	
⑭	LOCKING DEVICE	AISI 304	

2-PC. SCREWED END BALL VALVE



FAK-ARMATUREN Hamburg
Valve supplier for industry and shipbuilding

ART. NO.	MATERIAL
03 006 63...	BSP
03 007 63...	NPT

// DIMENSIONS

DN	d	D	L	H	H1	T	W	Torque (N-m)	Weight (kg)
8	11.6	19	50.8	58.5	18	3/8"-24UNF	100	3.5	0.2
10	12.5	22.5	50.8	58.5	18	3/8"-24UNF	100	4	0.2
15	15	26	58	58.5	18.5	3/8"-24UNF	100	5.5	0.3
20	20	32	65.6	63.5	22.5	7/16"-20UNF	125	7.5	0.5
25	25	38	78.7	78	25	7/16"-20UNF	149	11	0.8
32	32	48	90	83	26	7/16"-20UNF	149	15	1.1
40	38	54.8	105	102	30	1/2"-20UNF	190	20	1.8
50	50	67	124	108	30	1/2"-20UNF	190	40	2.7
65	63	85	146	138	40	3/4"-10UNF	250	60	5.6
80	76	100	164	146	40	3/4"-10UNF	250	85	7.5

unit: mm

NPS	d	D	L	H	H1	T	W	Torque (in-lb)	Weight (lb)
1/4"	0.46	0.75	2	2.3	0.71	3/8"-24UNF	3.94	31	0.5
3/8"	0.49	0.89	2	2.3	0.71	3/8"-24UNF	3.94	35.4	0.5
1/2"	0.59	1.02	2.28	2.3	0.73	3/8"-24UNF	3.94	48.7	0.7
3/4"	0.79	1.26	2.58	2.5	0.89	7/16"-20UNF	4.92	66.4	1
1"	0.98	1.5	3.1	3.07	0.98	7/16"-20UNF	5.87	97.4	1.7
1-1/4"	1.26	1.89	3.54	3.27	1.02	7/16"-20UNF	5.87	132.8	2.5
1-1/2"	1.5	2.16	4.13	4.02	1.18	1/2"-20UNF	7.48	177	3.9
2"	1.97	2.64	4.88	4.25	1.18	1/2"-20UNF	7.48	354	5.9
2-1/2"	2.48	3.35	5.75	5.43	1.57	3/4"-10UNF	9.84	531	12.4
3"	2.99	3.94	6.46	5.75	1.57	3/4"-10UNF	9.84	752.3	16.5

unit: in