



FAK-ARMATUREN GmbH

Zwischenflansch - Rückschlagklappe
 PN 10/16
 DN 40 - 900

swing check flap
 PN 10/16
 DN 40 - 900

Auch in anderen Druckstufen lieferbar

supply with other pressure ratings on request

Teil Part	Bezeichnung Partname	Werkstoff Material	Werkst.Nr. Mat.No.
1	Gehäuse body	st.steel	1.4301
2	Klappe flap	st.steel	1.4301
3	Scharnierteile partners of a hinge	st.steel	1.4301
4	Klappenwelle shaft	st.steel	1.4301
5	Dichtring O-ring sealing	VTITON/FPM	

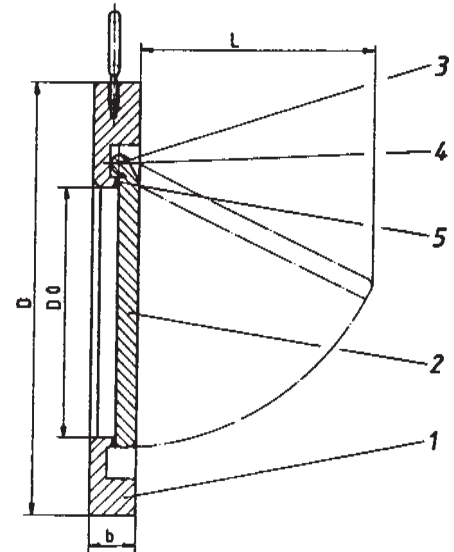

Auch mit anderen Materialkombinationen lieferbar

supply with other material combinations on request

DN	L	D	D 0	b	kg	Art. - Nr.	
40	30	95	22	14	0,8		0415063050
50	35	109	32	14	1		0415063050
65	48	129	40	14	1,3		0415063065
80	60	144	54	14	1,7		0415063080
100	78	164	70	18	2,2		0415063100
125	98	195	92	18	3,2		0415063125
150	117	220	114	20	5		0415063150
200	160	275	154	22	11		0415063200
250	200	332	200	26	15		0415063250
300	235	387	240	32	25		0415063300
350	258	447	270	38	37		0415063350
400	300	495	310	44	55		0415063400
450	331	557	360	44	65		0415063450
500	458	519	405	56	105		0415063500
600						auf	supply
700						Anfrage	request
800						lieferbar	on
900							