



Zwischenflansch - Rückschlagklappe
 PN 16
 DN 40 - 900

swing check flap
 PN 16
 DN 40 - 900

Auch in anderen Druckstufen lieferbar

supply with other pressure ratings on request

Teil Part	Bezeichnung Partname	Werkstoff Material	Werkst.Nr. Mat.No.
1	Gehäuse body	aluminiumbronze	
2	Klappe flap	aluminium bronze	
3	Scharnierteile partners of a hinge	bronze	
4	Klappenwelle shaft	X 5 Cr Ni 18 9	1.4301
5	Dichtring O-ring sealing	NBR or EPDM	

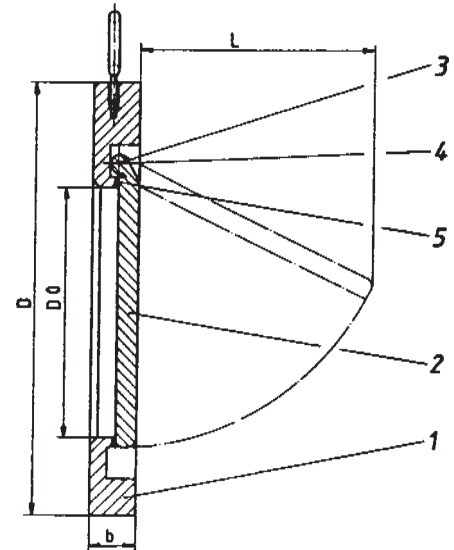

Auch mit anderen Materialkombinationen lieferbar

supply with other material combinations on request

DN	L	D	D 0	b	kg				Art. - Nr.
40	30	95	22	14	0,8				0415070050
50	35	109	32	14	1				0415070050
65	48	129	40	14	1,3				0415070065
80	60	144	54	14	1,7				0415070080
100	78	164	70	18	2,2				0415070100
125	98	195	92	18	3,2				0415070125
150	117	220	114	20	5				0415070150
200	160	275	154	22	11				0415070200
250	200	332	200	26	15				0415070250
300	235	387	240	32	25				0415070300
350	258	447	270	38	37				0415070350
400	300	495	310	44	55				0415070400
450	331	557	360	44	65				0415070450
500	458	519	405	56	105				0415070500
600									auf supply
700									Anfrage request
800									lieferbar on
900									