



Einfachfilter aus Gußeisen
 DN 50 - 300
 PN 10

single strainers cast iron with flanges
 DN 50 - 300
 PN 10

Bei Anfragen und Bestellungen bitte die Lochung des Bleches und die Filterfeinheit, sowie das Material der Siebgaze angeben!

please state plate perforation and mesh size, as well as material for mesh on request or order!

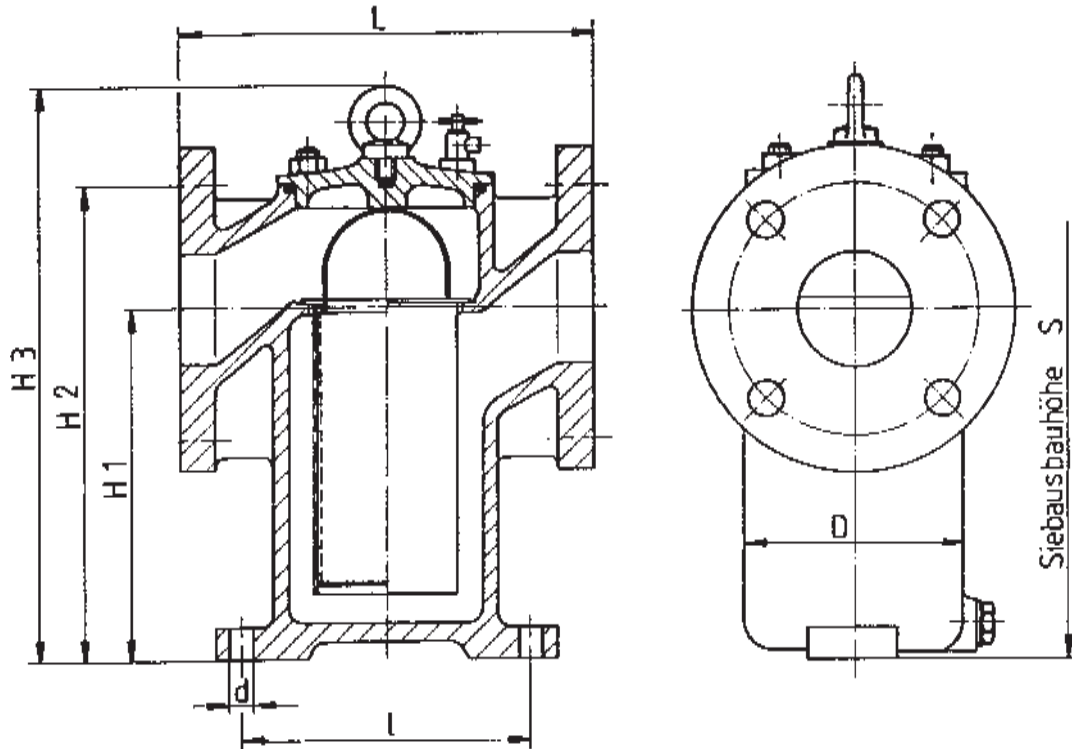

DN	PN	D	H1	H2	H3	L	l	S	d	kg	Durchflußleistung	Filterfläche Ringsieb	Filterfläche Korbsieb	Art.- Nr.
50	10	100	165	215	260	190	-	410	-	10	18	520	280	0505016050
65	10	125	200	270	330	230	160	510	12	20	30	710	450	0505016065
80	10	165	230	315	380	280	200	600	12	25	45	1120	750	0505016080
100	10	175	300	405	460	310	215	780	14	30	70	1500	1000	0505016100
125	10	220	325	455	520	380	260	875	14	50	110	2400	1350	0505016125
150	10	260	380	535	600	450	310	1025	18	70	160	2800	1950	0505016150
200	10	320	480	685	750	590	370	1330	23	120	280	5100	2950	0505016200
250	10	400	600	820	910	605	460	1585	23	200	440	8700	4700	0505016250
300	10	470	720	975	1060	720	530	1900	23	290	635	9900	6400	0505016300
											m ³ /h	cm ²	cm ²	