



FAK-ARMATUREN GmbH

Grobfilter , Form E , aus Grauguß , nach DIN 87151 , PN 2,5

strainer , type E , of cast iron , to DIN 87151 , PN 2,5

Teil Part	Bezeichnung Partname	Werkstoff Material	Werkst.Nr. Mat.No.
1	Gehäuse body	GG 25 / cast iron	0.6025
2	Deckel bonnet	GG 25 / cast iron	0.6025
3	Korb basket	st. steel	1.4301
4	Ringschraube lifting lug	C 15	1.0401
5	Dichtring gasket	Nitril	
6	Nietstift pin	Stahl	

Teil Part	Bezeichnung Partname	Werkstoff Material	Werkst.Nr. Mat.No.
7	Sechskantmutter nut	St. verzinkt	
8	Unterleg Scheibe washer	St. verzinkt	
9	Augenschraube eye bolt	St. verzinkt	
10	Verschlusschraube drain plug	MS	

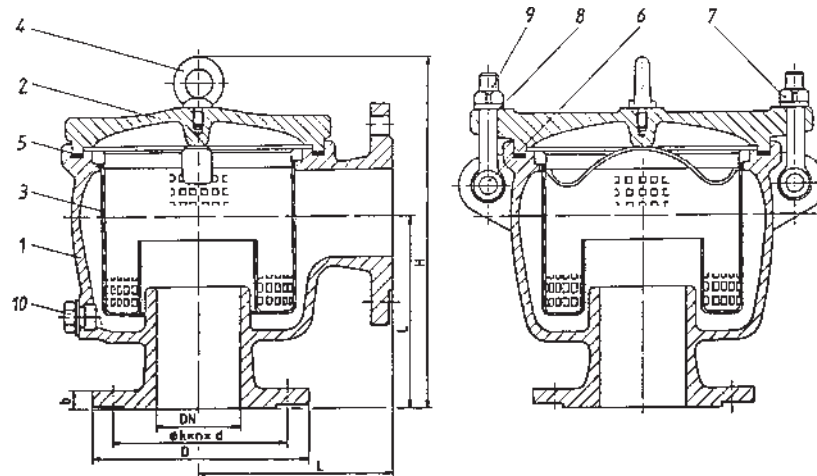

DN	L	H	D	ρk x n x d	b	kg				Art.- Nr.
32	125	240	140	100 x 4 x 18	16	16				0520101032
40	125	240	150	110 x 4 x 18	16	16,5				0520101040
50	135	255	165	125 x 4 x 18	18	21				0520101050
65	150	290	185	145 x 4 x 18	18	25				0520101065
80	175	320	200	160 x 8 x 18	20	35				0520101080
100	195	370	220	180 x 8 x 18	20	52				0520101100
125	220	410	250	210 x 8 x 18	22	66				0520101125
150	270	490	285	240 x 8 x 22	22	95				0520101150
175	300	535	315	270 x 8 x 22	24	122				0520101175
200	300	580	340	295 x 8 x 22	24	135				0520101200
250	390	650	395	350 x 12 x 22	26	212				0520101250
300	450	775	445	400 x 12 x 22	26	248				0520101300